

ПРЕДПРИЯТИЕ МАКСАЭРО

- Производство воздуховодов и систем вентиляции
- Клапаны противопожарные
- Клапаны дымоудаления
- Вентиляторы общепром, дымоудаления, крышные

220056, г. Минск, ул. Стариновская, 15

Тел./факс: +375 17 244-67-44, 258-67-51, 347-73-56, 252-54-27

Velcom: +375 29 603-88-99

E-mail: olegaero@yandex.by

www.maxaero.by



Когтевые вакуумные насосы MM 1324-1322 AV



Table of Contents

1 Safety	3
2 Product Description	4
2.1 Operating Principle.....	4
2.2 Application	5
2.3 Optional Accessories.....	5
2.3.1 Inlet Filter	5
2.3.2 Vacuum Relief Valve.....	5
3 Transport	5
4 Storage	6
5 Installation	7
5.1 Installation Conditions	7
5.2 Connecting Lines / Pipes	7
5.2.1 Suction Connection.....	8
5.2.2 Discharge Connection.....	8
5.3 Filling Oil.....	8
5.4 Electrical Connection	9
5.4.1 Wiring Diagram Three-Phase Motor	9
6 Commissioning	11
6.1 Conveying Condensable Vapours	11
7 Maintenance	12
7.1 Maintenance Schedule.....	12
7.2 Oil Level Inspection	12
7.3 Cleaning from Dust and Dirt.....	13
7.4 Oil Change	14
8 Overhaul	15
9 Decommissioning	15
9.1 Dismantling and Disposal.....	15
10 Spare Parts	16
11 Troubleshooting	17
12 Technical Data	19
13 Oil	19
14 EU Declaration of Conformity	20

1 Safety

Prior to handling the machine, this instruction manual should be read and understood. If anything needs to be clarified, please contact your Busch representative.

Read this manual carefully before use and keep for future reference.

This instruction manual remains valid as long as the customer does not change anything on the product.

The machine is intended for industrial use. It must be handled only by technically trained personnel.

The machine has been designed and manufactured according to state-of-the-art methods. Nevertheless, residual risks may remain. This instruction manual highlights potential hazards where appropriate. Safety notes and warning messages are tagged with one of the keywords DANGER, WARNING, CAUTION, NOTICE and NOTE as follows:

DANGER

... indicates an imminent dangerous situation that will result in death or serious injuries if not prevented.

WARNING

... indicates a potentially dangerous situation that could result in death or serious injuries.

CAUTION

... indicates a potentially dangerous situation that could result in minor injuries.

NOTICE

... indicates a potentially dangerous situation that could result in damage to property.

NOTE

... indicates helpful tips and recommendations, as well as information for efficient and trouble-free operation.

2 Product Description

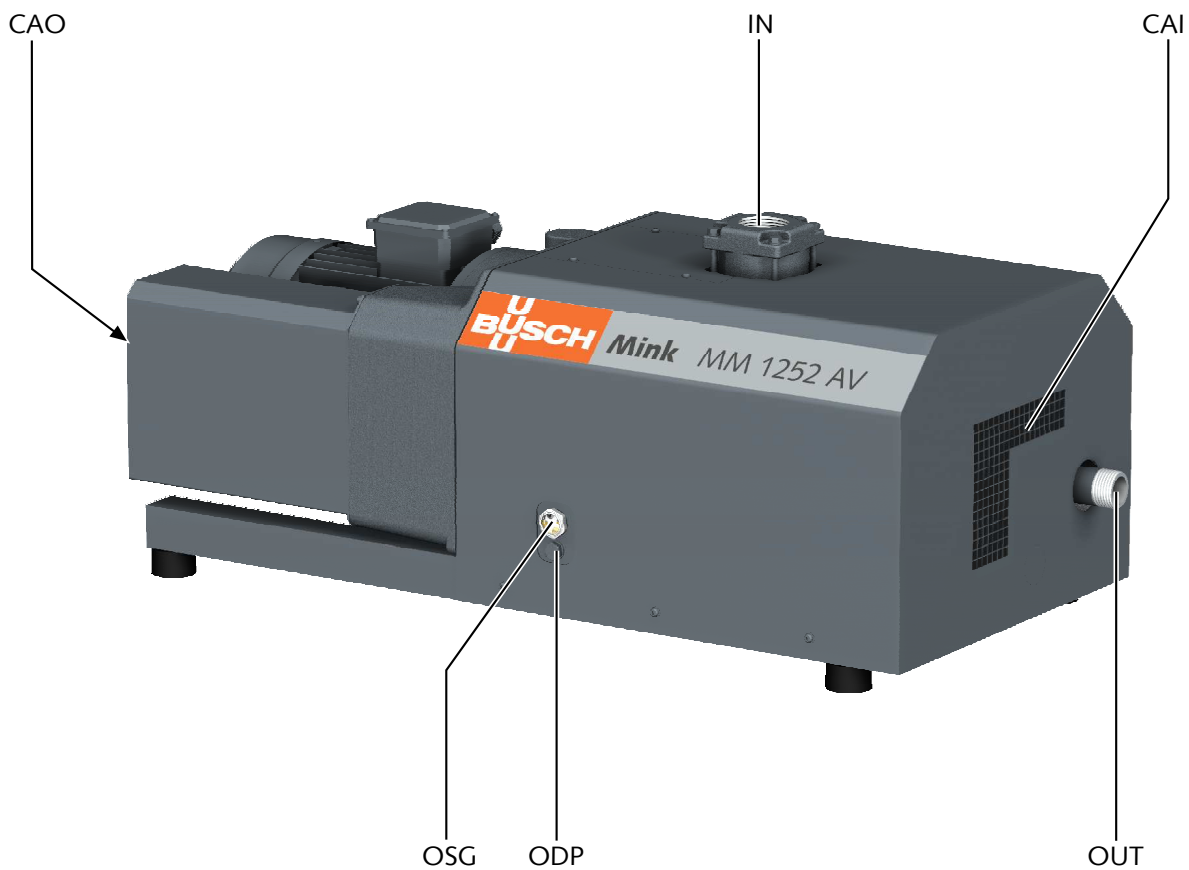

IN	Suction connection	ODP	Oil drain plug
OUT	Discharge connection	CAI	Cooling air inlet
OSG	Oil sight glass	CAO	Cooling air outlet

NOTE

Technical term.

In this instruction manual, we consider that the term 'machine' refers to the 'vacuum pump'.

2.1 Operating Principle

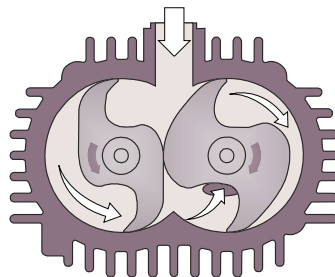

The machine works on the claw principle.

2.2 Application

The machine is intended for the suction of air and other dry, non-aggressive, non-toxic and non-explosive gases.

Conveying of other media leads to an increased thermal and/or mechanical load on the machine and is permissible only after a consultation with Busch.

The machine is intended for the placement in a non-potentially explosive environment.

The machine is not capable of maintaining ultimate pressure. The minimum allowed ultimate pressure is to be read from the nameplate of the machine. By means of process control and/or vacuum relief valves it must be made sure that the minimum allowed ultimate pressure will not be underrun.

The machine is thermally suitable for continuous operation:

- The continuous operation of MM1202 AV; MM 1252 AV; MM 1322 AV is limited to a suction pressure of 200 hPa.

In case of a lower suction pressure:

- The operating time in continuous operation is limited at 20 minutes, when operating up to ultimate pressure (see Technical Data [▶ 19]).
 - Ultimate suction pressure for MM 1202 AV; MM 1252 AV: 100 hPa
 - Ultimate suction pressure for MM 1322 AV: 150 hPa
- Afterwards the machine must cool down for at least the same amount of time, at a suction pressure range of 200... 1000 hPa.

Permitted environmental conditions see Technical Data [▶ 19].

2.3 Optional Accessories

2.3.1 Inlet Filter

The inlet filter protects the machine against dust and other solids in the process gas. The inlet filter is available with a paper or polyester cartridge.

2.3.2 Vacuum Relief Valve

The ultimate pressure is limited by a vacuum relief valve. The vacuum relief valve is adjusted ex-works to the minimum permitted ultimate pressure (see nameplate).

3 Transport



WARNING

Suspended load.

Risk of severe injury!

- Do not walk, stand or work under suspended loads.

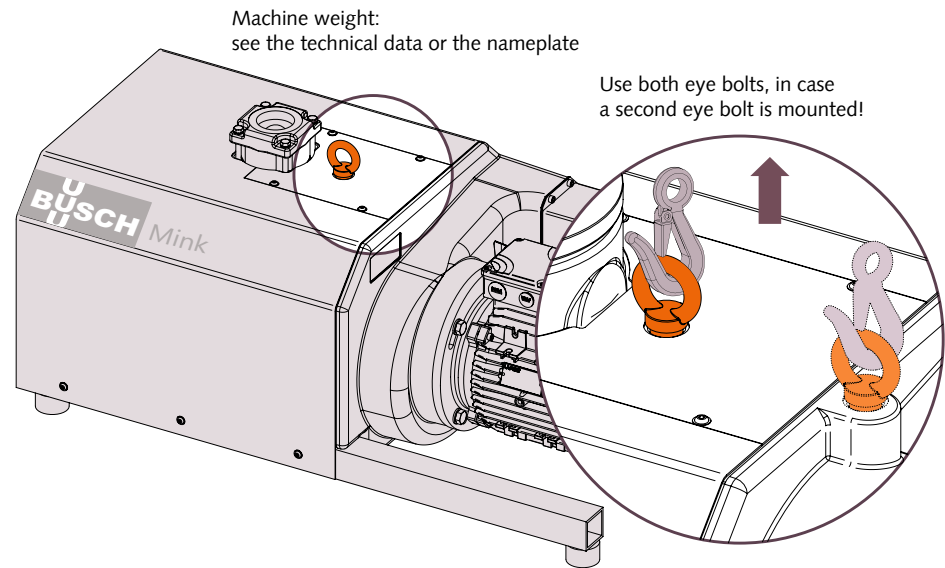

- Check the machine for transport damage.
- If the machine is secured to a base plate:
- Remove the machine from the base plate.

WARNING

Lifting the machine using the motor eye bolt.

Risk of severe injury!

- Do not lift the machine using the eye bolt fitted to the motor. Only lift the machine as previously shown.

4 Storage

- Seal all apertures with adhesive tape or reuse provided caps.
- If the machine is to be stored for more than 3 months:
- Wrap the machine in a corrosion inhibiting film.
 - Store the machine indoors, dry, dust free and if possible in original packaging preferably at temperatures between 0 ... 40 °C.

5 Installation

5.1 Installation Conditions

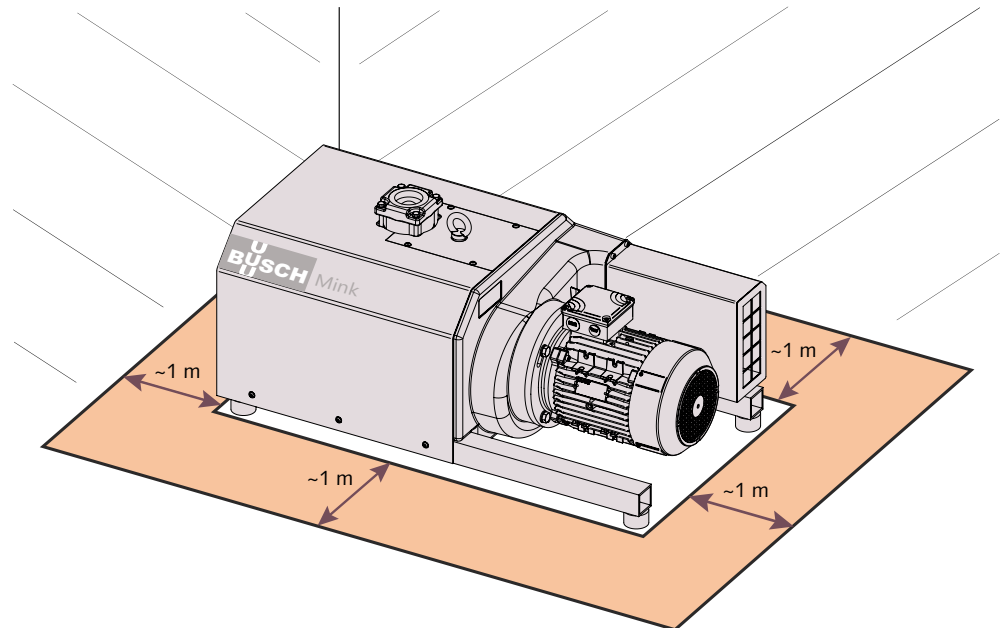

- Make sure that the environment of the machine is not potentially explosive.
- Make sure that the ambient conditions comply with the Technical Data [► 19].
- Make sure that the environmental conditions comply with the protection class of the motor.
- Make sure that the installation space or location is vented such that sufficient cooling of the machine is provided.
- Make sure that cooling air inlets and outlets are not covered or obstructed and that the cooling air flow is not affected adversely in any other way.
- Make sure that the oil sight glass (OSG) remains easily visible.
- Make sure that enough space remains for maintenance work.
- Make sure that the machine is placed or mounted horizontally, a maximum of 1° in any direction.
- Check the oil level, see Oil Level Inspection [► 12].
- Make sure that all provided covers, guards, hoods, etc. are mounted.

5.2 Connecting Lines / Pipes

- Make sure that the connection lines cause no stress on the machine's connection; if necessary use flexible joints.
- Make sure that the line size of the connection lines over the entire length is at least as large as the connections of the machine.

In case of very long connection lines it is advisable to use larger line sizes in order to avoid a loss of efficiency. Seek advice from your Busch representative.

5.2.1 Suction Connection

NOTICE

Intruding foreign objects or liquids.

Risk of damage to the machine!

If the inlet gas contains dust or other foreign solid particles:

- Install a suitable filter (5 micron or less) upstream from the machine.
-

Connection size:

- G2

Depending on the specific order, other connection dimensions may apply.

5.2.2 Discharge Connection

Connection size:

- R1 for MM 1324 AV, MM 1202 AV, MM 1252 AV
- R1 1/4 for MM 1322 AV

Depending on the specific order, other connection dimensions may apply.

- Make sure that the discharged gas will flow without obstruction. Do not shut off or throttle the discharge line or use it as a pressurised air source.

Unless the aspirated air is discharged to the environment right at the machine:

- Make sure that the discharge line either slopes away from the machine or provide a liquid separator or a siphon with a drain cock, so that no liquids can flow back into the machine.

5.3 Filling Oil

The oil level should stay constant over the lifetime of the oil. If the level does fall, the gear is leaky and the machine requires repair.

For oil type and oil capacity see Technical Data [▶ 19] and Oil [▶ 19].

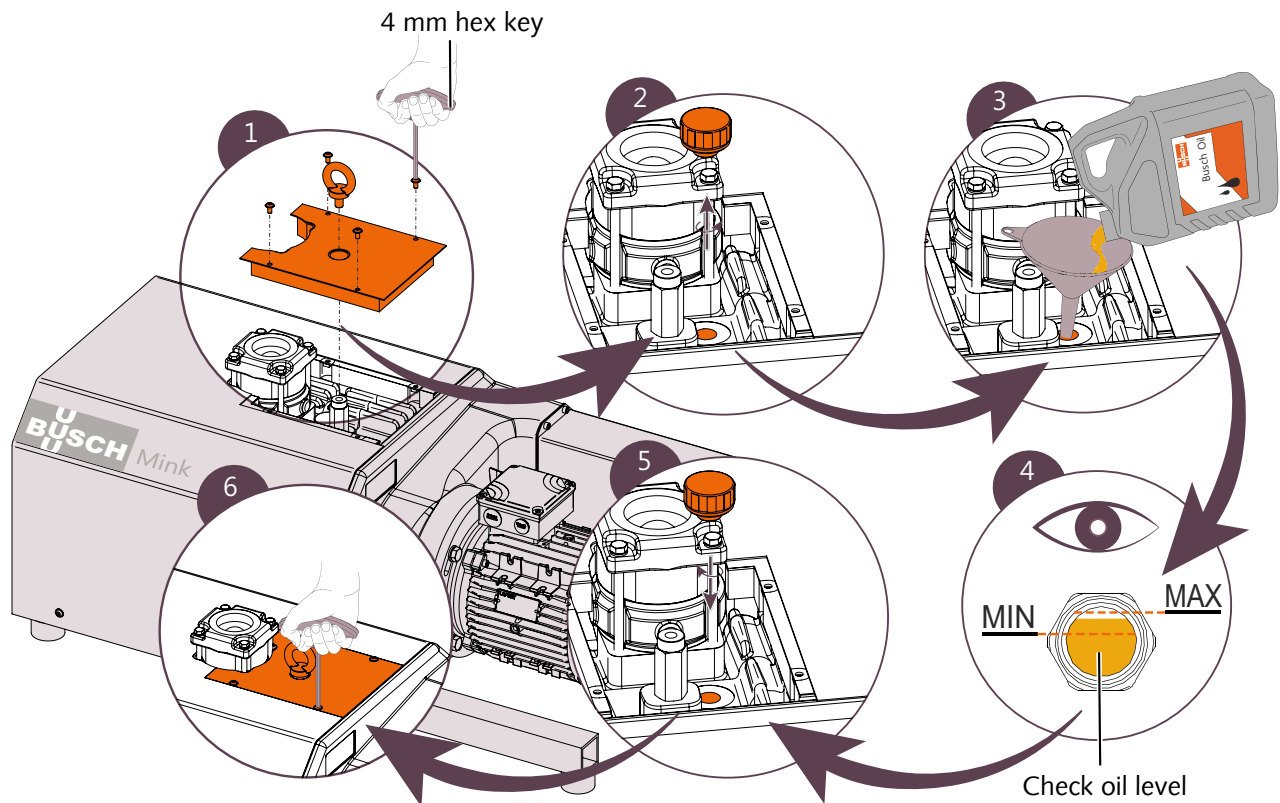

5.4 Electrical Connection

DANGER

Live wires.

Risk of electrical shock.

- Electrical installation work must only be executed by qualified personnel.
- Make sure that the power supply for the motor is compatible with the data on the nameplate of the motor.
- Provide overload protection according to EN 60204-1 for the motor.
- Make sure that the motor of the machine will not be affected by electric or electro-magnetic disturbance from the mains; if necessary seek advice from Busch.
- Connect the protective earth conductor.
- Electrically connect the motor.

NOTICE

Incorrect connection.

Risk of damage to the motor!

- The wiring diagrams given below are typical. Check the inside of the terminal box for motor connection instructions/diagrams.

5.4.1 Wiring Diagram Three-Phase Motor

Delta connection (low voltage):

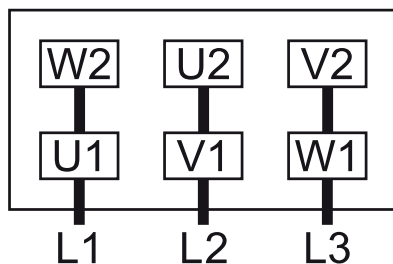

Star connection (high voltage):

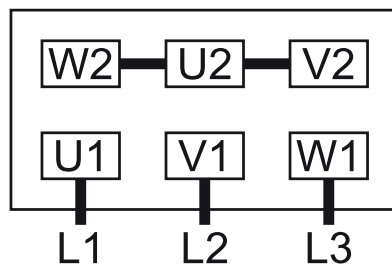

Double star connection, multi-voltage motor with 9 pins (low voltage):

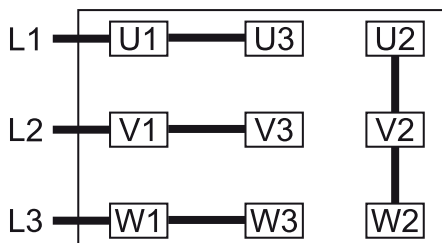

Star connection, multi-voltage motor with 9 pins (high voltage):

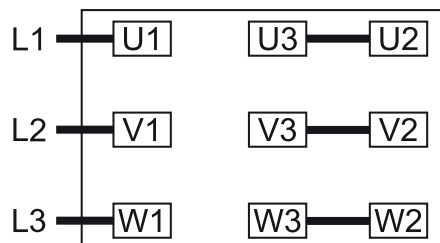

Double star connection, multi-voltage motor with 12 pins (low voltage):

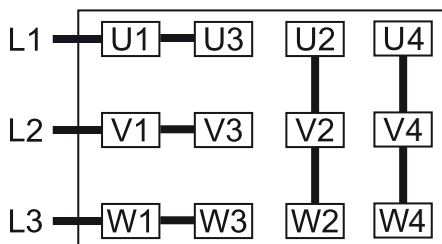

Star connection, multi-voltage motor with 12 pins (high voltage):

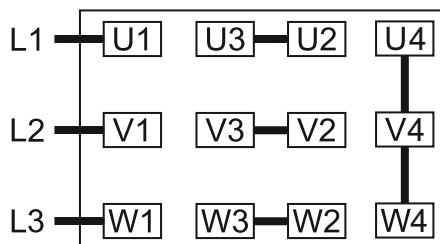

Delta connection, multi-voltage motor with 12 pins (middle voltage):

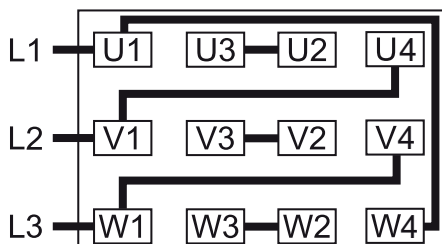

! NOTICE

Incorrect direction of rotation.

Risk of damage to the machine!

- Operation in the wrong direction of rotation can destroy the machine in a short time! Prior to start-up, ensure that the machine is operated in the right direction.

- Determine the intended direction of rotation with the arrow (stuck on or cast).
- Jog the motor briefly.

If the rotation must be changed:

- Switch any two of the motor phase wires.

6 Commissioning

NOTICE

Lubricating a dry running machine (process chamber).

Risk of damage to the machine!

- Do not lubricate the process chamber of the machine with oil or grease.

CAUTION

During operation the surface of the machine may reach temperatures of more than 70°C.

Risk of burns!

- Avoid contact with the machine during and directly after operation.



CAUTION

Noise of running machine.

Risk of damage to hearing!

If persons are present in the vicinity of a non noise insulated machine over extended periods:

- Make sure that ear protection is being used.
- Make sure that the installation conditions (see Installation Conditions [▶ 7]) are complied with.
- Switch on the machine.
- Make sure that the maximum permissible number of starts does not exceed 12 starts per hour.

As soon as the machine is operated under normal operating conditions:

- Measure the motor current and record it as reference for future maintenance and troubleshooting work.

6.1 Conveying Condensable Vapours

Water vapour within the gas flow is tolerated within certain limits. The conveyance of other vapours shall be agreed upon with Busch.

In order to use the machine for the conveyance of condensable vapours, the machine must be equipped with a corrosion protection coating (Aqua version) and a drain cock in the silencer.

If condensable vapours are to be conveyed:

Before process:

- Warm up the machine for approximately half an hour.

After process:

- Operate the machine for approximately another half an hour.
- Regularly drain condensate from the silencer with the drain cock.

7 Maintenance



 **WARNING**

Machines contaminated with hazardous material.

Risk of poisoning!

Risk of infection!

If the machine is contaminated with hazardous material:

- Wear appropriate personal protective equipment.

 **CAUTION**

Hot surface.

Risk of burns!

- Prior to any action requiring touching the machine, let the machine cool down first.

- Shut down the machine and lock against inadvertent start up.
- Vent the connected lines to atmospheric pressure.

If necessary:

- Disconnect all connections.

7.1 Maintenance Schedule

The maintenance intervals depend very much on the individual operating conditions. The intervals given below are desired to be considered as starting values which should be shortened or extended as appropriate. Particularly heavy duty operation, such as high dust loads in the environment or in the process gas, other contamination or ingress of process material, can make it necessary to shorten the maintenance intervals significantly.

Monthly	In case of an inlet filter being installed: <ul style="list-style-type: none"> • Check the inlet filter cartridge, replace if necessary.
Every 3 months	<ul style="list-style-type: none"> • Check the oil level, see Oil Level Inspection [▶ 12].
Every 6 months	<ul style="list-style-type: none"> • Clean the machine from dust and dirt.
Every 20000 hours	<ul style="list-style-type: none"> • Change the oil. <p>The change interval of 20000 operating hours is valid for Busch approved oils only. The change interval depends very much on the operating conditions. Borderline operation may reduce the change interval down to approximately 5000 operating hours. Other oils may reduce the change interval.</p>
Every 6 years	<ul style="list-style-type: none"> • Have a major overhaul on the machine (contact Busch).

7.2 Oil Level Inspection

- Shut down the machine.
- When the machine is stopped, wait 1 minute before checking the oil level.

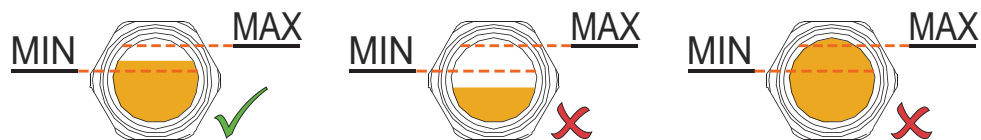

The oil level should stay constant over the lifetime of the oil. If the level does fall, the gear is leaky and the machine requires repair.

- Fill up if necessary, see Oil Filling [▶ 8].

7.3 Cleaning from Dust and Dirt

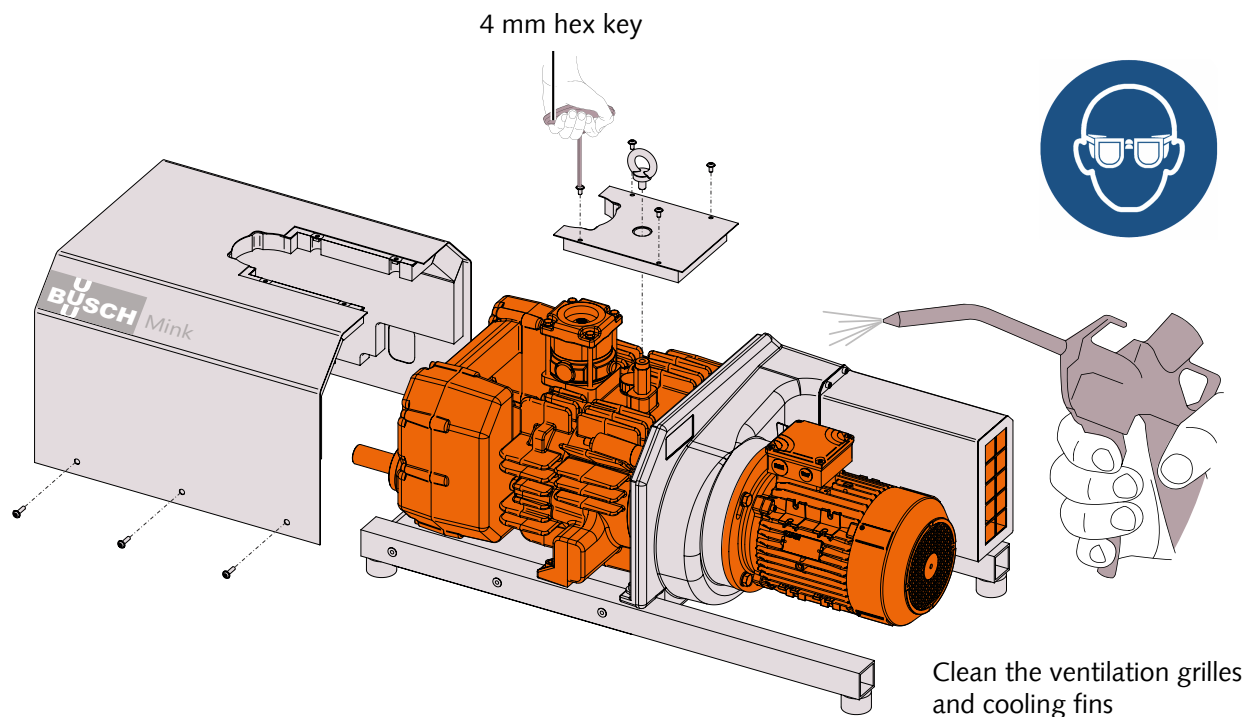

7.4 Oil Change

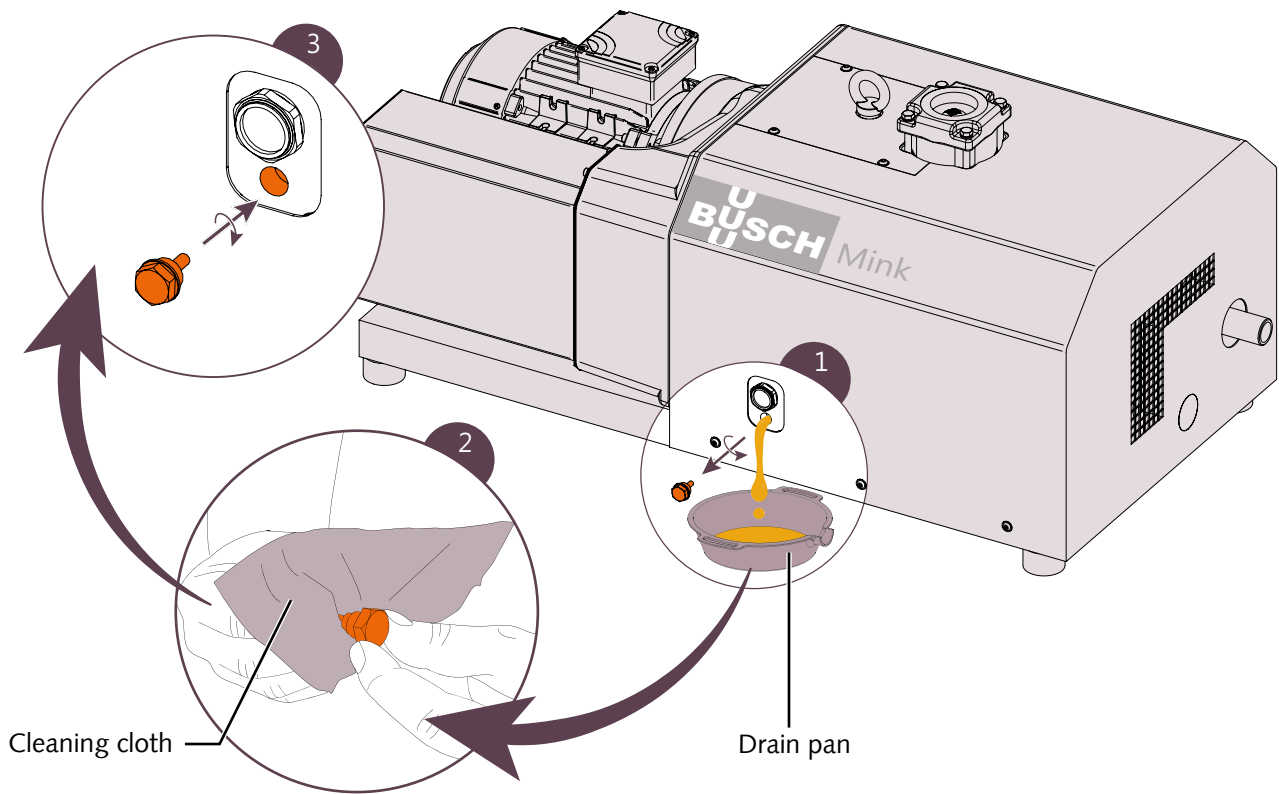

The oil level should stay constant over the lifetime of the oil. If the level does fall, the gear is leaky and the machine requires repair.

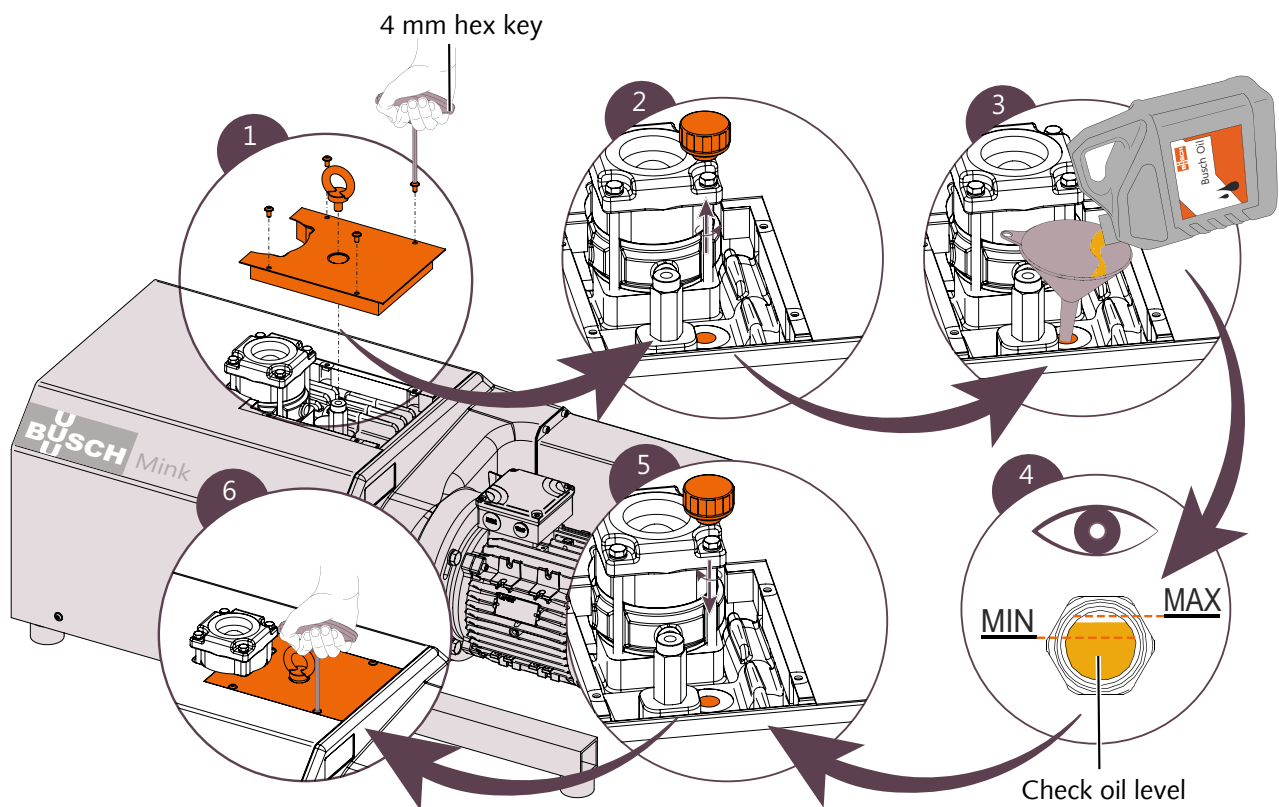

8 Overhaul

NOTICE

Improper assembly.

Risk of premature failure!

Loss of efficiency!

- It is highly recommended that any dismantling of the machine that goes beyond anything that is described in this manual should be done through Busch.



WARNING

Machines contaminated with hazardous material.

Risk of poisoning!

Risk of infection!

If the machine is contaminated with hazardous material:

- Wear appropriate personal protective equipment.

In case of the machine having conveyed gas that was contaminated with foreign materials which are dangerous to health:

- Decontaminate the machine as well as possible and state the contamination status in a 'Declaration of Contamination'.

Busch will only accept machines that come with a completely filled in and legally binding signed 'Declaration of Contamination'.

(Form downloadable from www.buschvacuum.com)

9 Decommissioning

- Shut down the machine and lock against inadvertent start up.
- Vent the connected lines to atmospheric pressure.
- Disconnect all connections.

If the machine is going to be stored:

- See Storage [▶ 6].

9.1 Dismantling and Disposal

- Drain the oil.
- Separate special waste from the machine.
- Dispose of special waste in compliance with applicable regulations.
- Dispose of the machine as scrap metal.

10 Spare Parts

NOTICE

Use of non-Busch genuine spare parts.

Risk of premature failure!

Loss of efficiency!

- The exclusive use of Busch genuine spare parts and consumables is recommended for the proper function of the machine and for granting of warranty.

Spare part	Description	Part no.
Oil fill plug (=Venting valve)	Includes appropriate seal ring	0543 107 407
Oil sight glass		0583 000 001
Seal ring	For oil sight glass	0480 000 271
Oil drain plug	Includes appropriate seal ring	0415 134 870
Seal ring	For oil drain plug	0482 137 352
Inlet flange lower part	Includes non-return valve	0915 000 670
Inlet screen		0534 000 041

If other parts are required:

- Contact your Busch representative for the detailed spare parts list.

11 Troubleshooting

DANGER

Live wires.

Risk of electrical shock.

- Electrical installation work must only be executed by qualified personnel.

CAUTION

Hot surface.

Risk of burns!

- Prior to any action requiring touching the machine, let the machine cool down first.

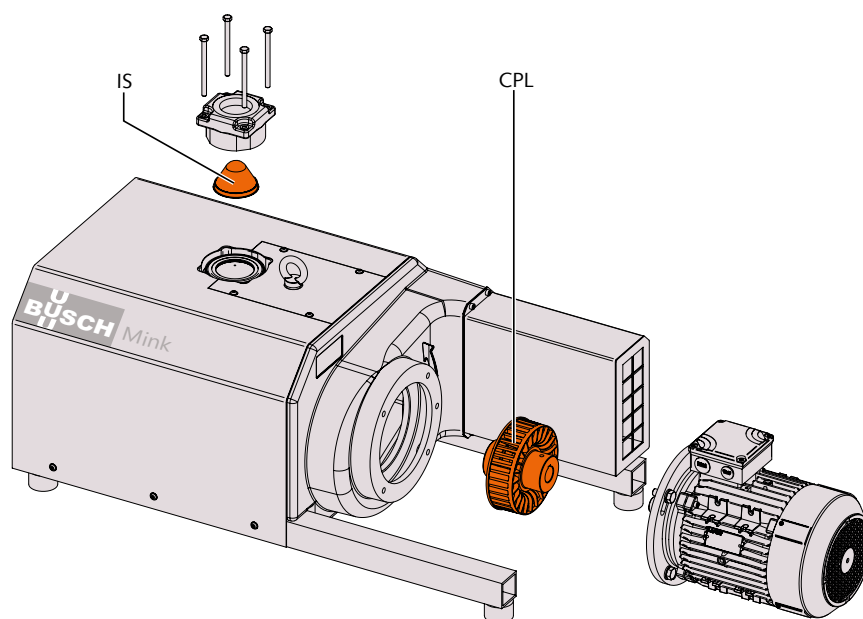

Problem	Possible Cause	Remedy
The machine does not start.	The motor is not supplied with the correct voltage.	• Check the power supply.
	The motor is defective.	• Replace the motor.
	The coupling (CPL) is defective.	• Replace the coupling (CPL).
The machine does not reach the usual pressure on the suction connection.	The inlet screen (IS) is partially clogged.	• Clean the inlet screen (IS).
	The inlet filter cartridge (optional) is partially clogged.	• Replace the inlet filter cartridge.
	Internal parts are worn or damaged.	• Repair the machine (contact Busch).
The machine runs very noisily.	Worn coupling (CPL).	• Replace the coupling (CPL).
	Oil level too low.	• Top up oil.
	Defective bearings.	• Repair the machine (contact Busch).

The machine runs too hot.	Insufficient cooling.	<ul style="list-style-type: none"> Remove dust and dirt from the machine.
	Ambient temperature too high.	<ul style="list-style-type: none"> Observe the permitted ambient temperature, see Technical Data [▶ 19].
	Temperature of the process gases at the inlet too high.	<ul style="list-style-type: none"> Observe the permitted gas inlet temperature, see Technical Data [▶ 19].
	Oil level too low.	<ul style="list-style-type: none"> Top up oil.

For the solution of problems not mentioned in the troubleshooting chart contact your Busch representative.

12 Technical Data

		MM 1202 AV		MM 1252 AV		MM 1322 AV		MM 1324 AV	
Nominal pumping speed (50Hz / 60Hz)	m ³ /h	200 / 240		245 / 290		300 / 360		250 / -	250 / 300
Ultimate pressure	hPa (mbar) abs.	see nameplate							
Nominal motor rating (50Hz / 60Hz)	kW	4.2 / 5.2	4.3 / 5.5	5.0 / -	5.1 / 6.8	6.0 / -	6.0 / 6.5	3.0 / -	4.0 / 4.2
Motor speed range	min ⁻¹	600 - 3600						600 - 1800	
Noise level (EN ISO 2151) at 400 hPa (mbar) abs. suction pressure (50Hz / 60Hz)	dB(A)	75 / 79				77 / 82		70 / 74	
Ambient temperature range	°C	0 ... 40							
Ambient pressure		Atmospheric pressure							
Oil capacity	l	1.0							
Weight approx. (50Hz / 60Hz)	kg	~240 / 245		~240 / 290		~260 / 300		~240 / 270	

13 Oil

	VS 150	VSB 100
ISO-VG	150	100
Part number 1 L packaging	0831 164 883	0831 168 351
Part number 5 L packaging	0831 164 884	0831 168 352
Remark	Standard oil for non-demanding applications	Food applications (H1)

14 EU Declaration of Conformity

This Declaration of Conformity and the CE-mark affixed to the nameplate are valid for the machine within the Busch scope of delivery. This Declaration of Conformity is issued under the sole responsibility of the manufacturer. When this machine is integrated into a superordinate machinery the manufacturer of the superordinate machinery (this can be the operating company, too) must conduct the conformity assessment process for the superordinate machine or plant, issue the Declaration of Conformity for it and affix the CE-mark.

The manufacturer

Busch Produktions GmbH
Schauinslandstr. 1
DE-79689 Maulburg



declare that the machine(s): **Mink MM 1324 AV; MM 1202 AV; MM 1252 AV; MM 1322 AV**
 with a serial number from **D1701...** to **D1852...**

has (have) been manufactured in accordance with the European Directives:

- 'Machinery' 2006/42/EC
- 'Electromagnetic Compatibility' 2014/30/EU
- 'RoHS' 2011/65/EU, restriction of the use of certain hazardous substances in electrical and electronic equipment

and following the standards.

Standard	Title of the Standard
EN ISO 12100:2010	Safety of machinery - Basic concepts, general principles of design
EN ISO 13857:2008	Safety of machinery - Safety distances to prevent hazard zones being reached by the upper and lower limbs
EN 1012-1:2010 EN 1012-2:1996 + A1:2009	Compressors and vacuum pumps - Safety requirements - Part 1 and Part 2
EN ISO 2151:2008	Acoustics - Noise test code for compressors and vacuum pumps - Engineering method (grade 2)
EN 60204-1:2006	Safety of machinery - Electrical equipment of machines - Part 1: General requirements
EN 61000-6-2:2005	Electromagnetic compatibility (EMC) - Generic standards. Immunity for industrial environments
EN 61000-6-4:2007 + A1:2011	Electromagnetic compatibility (EMC) - Generic standards. Emission standard for industrial environments
EN ISO 13849-1:2015 ⁽¹⁾	Safety of machinery - Safety-related parts of control systems - Part 1: General principles for design

Person authorised to compile the technical file:

Gerd Rohweder
 Busch Dienste GmbH
 Schauinslandstr. 1
 DE-79689 Maulburg

Maulburg, 08.01.2017

Martin Gutmann, General director

⁽¹⁾ In case control systems are integrated.